

DAC60000 INSTALLATION

19" and Wall Mounting Adapters for Inverters

19" INSTALLATION

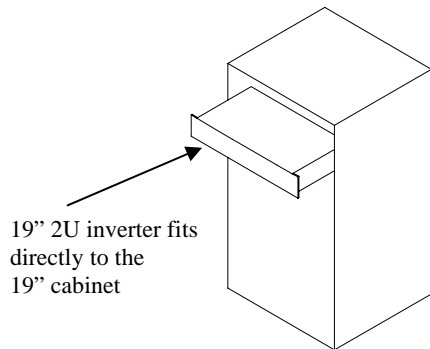

19" 2U inverter fits directly to the 19" cabinet

19" 6U sub-rack fits to the 19" cabinet

6U 14TE inverter module fits to 19" 6U sub-rack

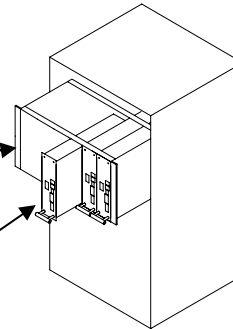

Type: 68200014
Sub-rack
19" x 6U x 300mm
(Note: depth of inverter 372mm)

Type: 8860000C
Covering plate for empty module place

Stand alone or parallel use

- 1...n pcs of 2U models in 19" cabinet

Parallel or stand alone use

- 1...6 pcs of inverters in 19" 6U sub-rack, OR
- 1...5 pcs of inverters and 1 static switch 19" 6U sub-rack

WALL MOUNTING FOR 1...3 MODULES

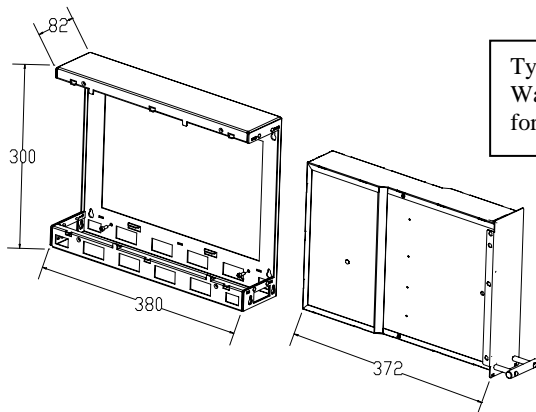

Type: WMA7830
Wall mounting adapter for 6U 14TE inverter

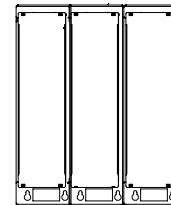

Max 3 pcs of wall mounting adapters can be mounted to one compact wall mountable package to include:

Stand alone or parallel use

- 1...3 inverters or
- Static switch + 1...2 inverters

WALL MOUNTABLE SUB-RACKS FOR 1...6 MODULES

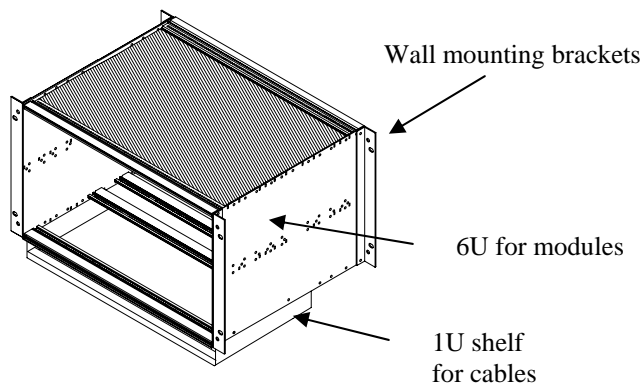

Type: 8868000
Wall mountable sub-rack
Shielded enclosure
19" x 7U x 475mm

Type: 8860000C
Cover plate for empty module place